

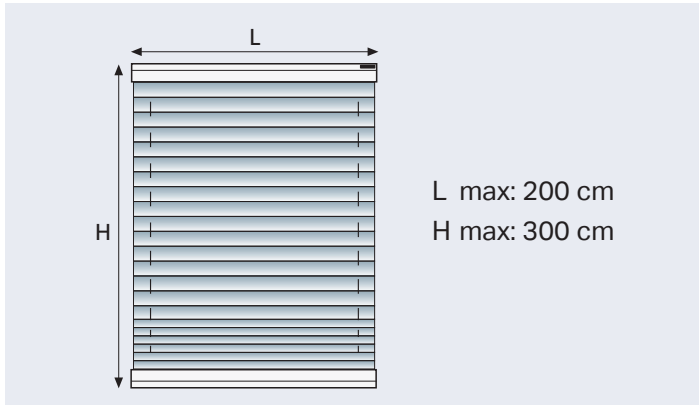

10.1.2

PLÌ 353/1

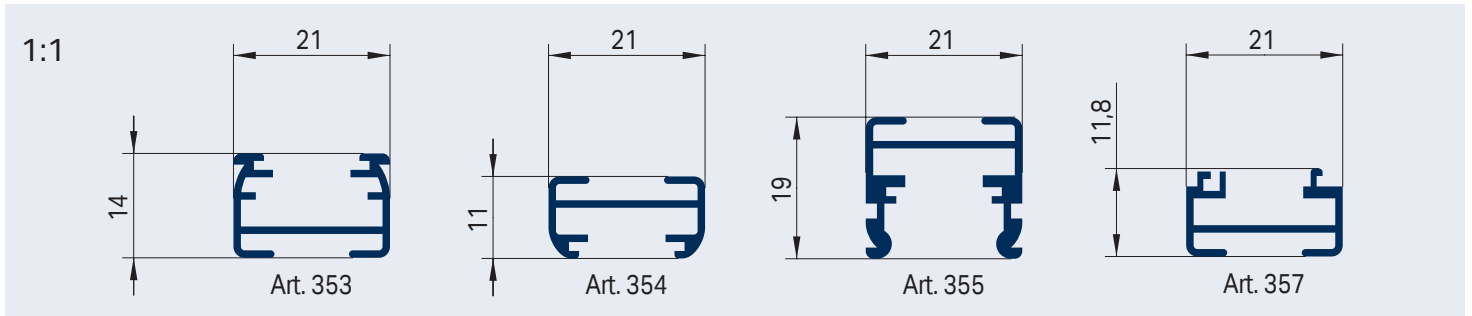



USE UTILIZZO - USE - USO
USO - UTILISATION - ANWENDUNG
GEBRUIK - ИСПОЛЬЗОВАНИЕ

SISTEMA PER TENDE PLISSETTATE CON PIEGHE DA 20 mm

Indicato per installazioni domestiche e professionali.
Scorrimento verticale, inclinato.
Indicato per tende filtranti e semioscuranti max 200x300 cm.
Azionamento con corde.
Arresto frontale a ghigliottina ultrapiatto.
L'installazione, preferibilmente su serramento o direttamente a soffitto, è con supporti a scatto che facilitano la rimozione del profilo.

PLEATED BLIND SYSTEM WITH 20 mm PLEATS

Suitable for domestic and professional installations.
Vertical and sloping sliding.
Suitable for filtering and semi-dimming blinds 200x300 cm max.
Cord operated.
Ultra-flat guillotine front stop.
Installation, preferably on the frame or directly on the ceiling, is by click supports that facilitate track removal.

SISTEMA DE CORTINAS PLISADAS CON PLIEGUES DE 20 mm

Indicado para instalaciones domésticas y profesionales.
Deslizamiento vertical o inclinado.
Indicado para cortinas filtrantes o semioscurecientes máx. 200 x 300 cm.
Accionamiento mediante cordones.
Parada frontal de guillotina ultraplano.
La instalación, preferiblemente en ventana o directamente en el techo, se efectúa con soportes a presión que facilitan el desmontaje del perfil.

SISTEMA PARA CORTINAS PLISSADAS COM PREGAS DE 20 mm

Indicado para instalações domésticas e profissionais.
Deslizamento vertical e inclinado. Indicado para cortinas filtrantes

e de semi-escurecimento máx 200x300 cm.

Accionamento com cordões.

Paragem frontal de guilhotina ultra-plano.

A instalação, de preferência no caixilho ou directamente no tecto, é feita com suportes de pressão que facilitam a remoção do perfil.

SYSTÈME POUR STORES PLISSÉS AVEC PLIS DE 20 mm

Conseillés pour locaux domestiques et professionnels.
Coulissement vertical, incliné.
Indiqué pour stores filtrants et semi-occultants max 200x300 cm.
Actionnement par drisses.
Arrêt frontal à guillotine ultra-plat.
L'installation, de préférence sur croisée ou directement au plafond, est réalisée sur supports encliquetable qui facilitent le retrait du profil.

PLISSEE MIT 20 mm-FALTEN

Für den privaten Haushalt und den Arbeitsbereich.
Vertikale oder schräge Führung.
Für Blendschutzstoff und teilweise abdunkelnden Stoff geeignet max. 200x300 cm.
Schnurbetätigung.
Sehr flache Frontale Arretierung.
Befestigung mit Einrasthalterungen aus gehärtetem und vernickeltem Spannstahl.
Die Montage erfolgt vorzugsweise am Fenster oder direkt an der Decke mit Einrasthalterung, so dass das Profil leicht zu entfernen ist.

PLISSÉSYSTEEM MET 20 mm PLOOIBREEDTE

Voor privaat en professioneel gebruik.
Toepassing voor verticale en schuine ramen.
Gebruik met verduisterende en filterende stoffen max. 200 cm x 300 cm.
Extra plat Koordbediend. Frontale rem.
Plaatsing op het raam, of tegen de wand of het plafond.

СИСТЕМА ДЛЯ ПЛИССЕРОВАННЫХ ШТОР СО СКЛАДКАМИ 20 мм

Предназначена для установки в жилых и офисных помещениях.
Вертикальное и наклонное открытие.
Предназначена для фильтрующих и полузатемняющих штор макс. 200x300 см.
Приведение в действие кордом.
Ультра-плоский передний блокиратор корда
Боковой блокиратор корда с битенгом.
Установка, желателно на оконную раму или непосредственно на потолок, выполняется при помощи защелкивающихся суппортов, облегчающих демонтаж профиля.

**CARATTERISTICHE TECNICHE - SPECIFICATIONS
CARACTERÍSTICAS - CARACTERÍSTICAS - CARACTÉRISTIQUES
EIGENSCHAFTEN - KARAKTERISTIEKEN - ХАРАКТЕРИСТИКИ**

- Profilo superiore ed inferiore in lega d'alluminio estrusa 6060 T6-UNI 8278
 - Profilo superiore Larghezza 21 mm Altezza 14 mm
 - Profilo inferiore Larghezza 21 mm Altezza 11 mm
 - Profilo porta tessuto in ABS estruso
 - Finitura superficiale:
verniciatura poliester bianco RAL 9016 lucido - nero RAL 9005 lucido - vaniglia RAL 1013;
anodizzato argento, bronzo
altri colori a richiesta
 - Accessori in acetilica autolubrificante
 - Arresto in poliammide antiusura
-
- 6060 T6 UNI 8278 extruded aluminium alloy upper and lower track
 - Upper track: Width 21 mm; Height 14 mm
 - Lower track: Width 21 mm; Height 11 mm
 - Extruded ABS fabric holder track
 - Surface finish: RAL 9016 white polished - RAL 9005 black polished - RAL 1013 vanilla;
silver, bronze anodised
available on request
 - Self-lubricating acetylic accessories
 - Wearproof polyamide stop
-
- Perfil superior e inferior en aleación de aluminio extruido 6060 T6-UNI 8278
 - Perfil superior: Anchura 21 mm - Altura 14 mm
 - Perfil inferior: Anchura 21 mm - Altura 11 mm
 - Perfil portatejido en ABS extruido
 - Acabados de la superficie:
pintura poliéster blanca RAL 9016 brillante - negra RAL 9005 brillante - vainilla RAL 1013;
Anodizado plata, bronce
otros colores bajo petición
 - Accesorios en acetálico autolubrificante
 - Freno de poliamida antiroce
-
- Perfis superior e inferior de liga de alumínio extrudido 6060 T6-UNI 8278
 - Perfis superior: Largura 21 mm; Altura 14 mm
 - Perfis inferior: Largura 21 mm; Altura 11 mm
 - Perfil porta-tecido em ABS extrudido
 - Acabamento superficial:
tinta de poliéster branca RAL 9016 polido - preta RAL 9005 polido - vermelha RAL 1013;
anodizado prateado, bronze
outras cores a pedido
 - Acessórios de resina acetálica autolubrificante
 - Batente de paragem de poliamida anti-desgaste
-
- Profil supérieur et inférieur en alliage d'aluminium extrudé 6060 T6-UNI 8278
 - Profil supérieur: Largeur 21 mm; Hauteur 14 mm
 - Profil inférieur: Largeur 21 mm; Hauteur 11 mm
 - Profil porte-tissu en ABS extrudé
 - Finition superficielle:
peinture polyester blanc RAL 9016 brillant - noir RAL 9005 brillant - vanille RAL 1013;
anodisé argent, bronze
autres couleurs sur demande
 - Accessoires en résine d'acétal autolubrificante
 - Arrêt en polyamide anti-usure
-
- Oberes und unteres Profil aus eloxiertem Aluminium 6060 T6-UNI 8278
 - Oberes Profil: Breite 21 mm; Höhe 14 mm
 - Unteres Profil: Breite 21 mm; Höhe 11 mm
 - Stoffhalteprofil aus extrudiertem ABS
 - Oberflächen-Finish:
Polyesterlackierung Weiß RAL 9016 poliert - Schwarz RAL 9005 poliert - Vanille RAL 1013
Alu eloxiert, Bronze
andere Farben auf Anfrage
 - Zubehör aus selbstschmierendem Acetal
 - Arretierung aus stoßfestem Polyamid
-
- 6060 T6 UNI 8278 aluminium boven- en onderprofiel
 - Bovenprofiel: Breedte 21 mm - hoogte 14 mm
 - Onderprofiel: Breedte 21 mm - hoogte 11 mm
 - ABS profiel voor de bevestiging van de stof
 - Oppervlaktebehandeling: RAL 9016 wit polyesterlak gepolijst - RAL 9005 zwart polyesterlak gepolijst - vanille RAL 1013 zilver en brons geanodiseerd
andere kleuren op aanvraag
 - Zelfsmerende acetyl onderdelen
 - Polyamide eindstop
-
- Верхний и нижний профиль из экструдированного алюминия 6060 T6 UNI 8278
 - Ширина верхнего профиля 21 мм; Высота 14 мм
 - Ширина нижнего профиля 21 мм; Высота 11 мм
 - Несущий штору профиль из экструдированного ПВХ
 - Отделка поверхности:
полиэфирная окраска в белый цвет RAL 9016 полированный, в черный цвет RAL 9005 полированный; ваниль RAL 1013 -
Анодирование серебро - бронза
другие цвета — по запросу
 - Аксессуары из самосмазывающейся ацеталовой пластмассы
 - Блокатор корда из износостойкого полиамида



APERTURA - OPENING - APERTURA - ABERTURA - OUVERTURE - AUFZUG - OPENEN - ОТКРЫТИЕ



VERSIONE STANDARD
Standard Version

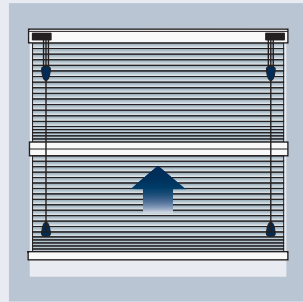

VERSIONE B
B Version

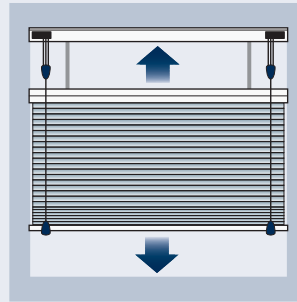

VERSIONE C
C Version

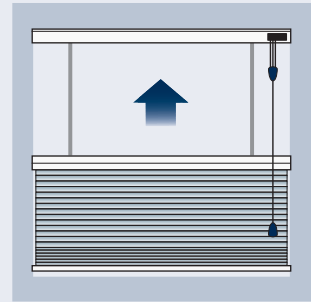

VERSIONE D
D Version

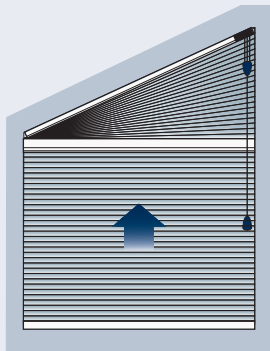

VERSIONE E
E Version

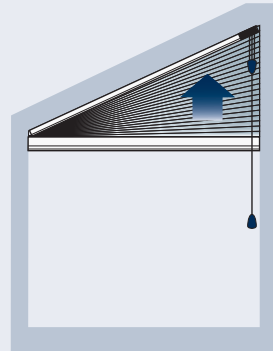

VERSIONE F
F Version

TENDE GUIDATE - GUIDED BLINDS - CORTINAS CON GUÍAS - CORTINAS COM GUIAS - PLISSÉ GUIDÉ - PLISSEE VERPANNT - PLISSÉ MET ZIJGELEIDING - ШТОРЫ С НАПРАВЛЯЮЩИМИ

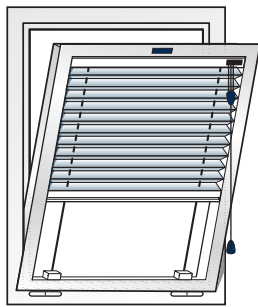

max 15°

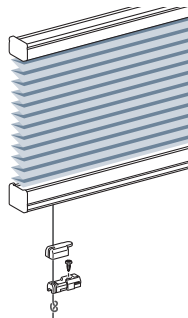

- Per l'applicazione su finestre inclinate e/o basculanti (non disponibile nelle versioni E e F)
- For use on raking and/or swinging window (not available in versions E and F)
- Para aplicación en ventanas inclinadas o basculantes (no disponible en las versiones E y F)
- Para aplicação em janelas inclinadas e/ou basculantes (não disponível nas versões E e F)
- Pour l'utilisation sur chassis ouvrants (non disponible dans les versions E et F)
- Für Dachschrägen und Kipfenster (nicht verfügbar in den Versionen E und F)
- Voor gebruik op kantelende ramen (niet beschikbaar in versies E en F)
- Для установки на наклонных или качающихся окнах (не доступны в версиях E и F)

INGOMBRI - OVERALL DIMENSIONS - ESPESORES - DIMENSÃO - ENCOMBREMENT - RAUMBEDARF - ПАКЕТ - ГАБАРИТЫ

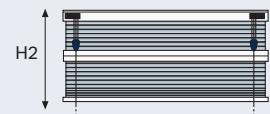
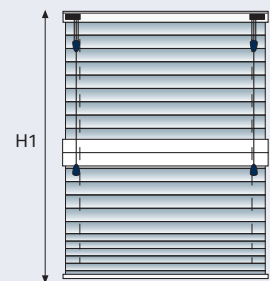
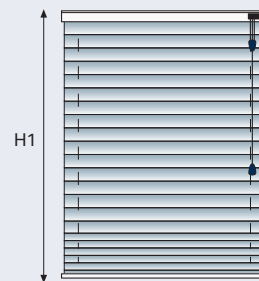

L max 200 cm
H1 max 300 cm
L min 15 cm
H2 min 30 cm

L max 150 cm
H1 max 300 cm
L min 15 cm
H2 min 30 cm

| H1 | H2 |
|--------|---------|
| 50 cm | ≈ 5 cm |
| 100 cm | ≈ 6 cm |
| 150 cm | ≈ 7 cm |
| 200 cm | ≈ 8 cm |
| 250 cm | ≈ 9 cm |
| 300 cm | ≈ 10 cm |

| H1 | H2 |
|--------|---------|
| 50 cm | ≈ 9 cm |
| 100 cm | ≈ 11 cm |
| 150 cm | ≈ 13 cm |
| 200 cm | ≈ 15 cm |
| 250 cm | ≈ 17 cm |
| 300 cm | ≈ 19 cm |

INSTALLAZIONE - INSTALLATION - INSTALACIÓN - INSTALAÇÃO - INSTALLATION - INSTALLATION - INSTALLATIE - УСТАНОВКА

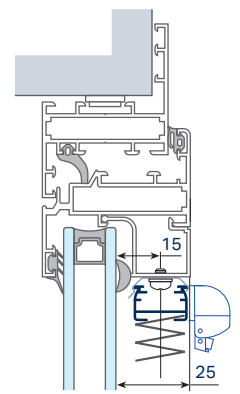
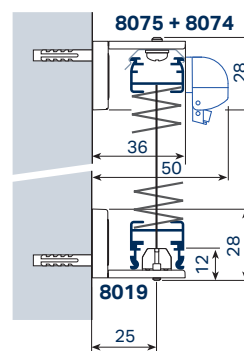
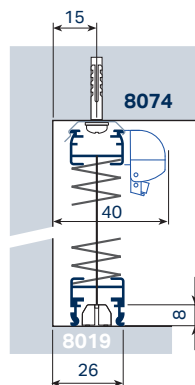
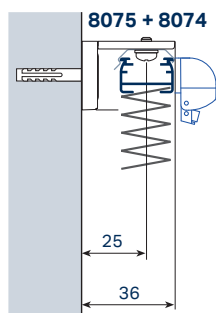
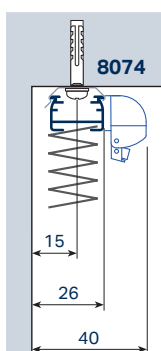



10.1.6

PLÌ 353/1

